



ZODIAC

LM Series

*Instruction Manual
& Warranty Card*



Zodiac, *Mastering the Elements*

Renowned worldwide for the quality and reliability of its products in the aeronautical and marine sectors, Zodiac has now brought its expertise to swimming pools, to bring you a full range of pools, automatic pool cleaners and water treatment systems.

Backed by Clearwater technology, expertise and experience, Zodiac brings you the reassurance of top quality equipment in terms of both design and performance.

A real guarantee of efficiency and peace of mind!

Dear Customer,

Congratulations on having purchased a Zodiac LM Series for your pool or spa. You have made a wise decision and you will benefit from your chlorinator for many years to come.

There are two major benefits in owning a Zodiac Saltwater Chlorinator. The first is that you will save hundreds of dollars which you otherwise would have to spend on sanitising chemicals for your pool or spa. Not only do you save money, but an even greater benefit which you will experience is the remarkable clarity of the water, and the pleasure and exhilaration of bathing in slightly salty water. By following just a few simple steps, your pool or spa will be a thing of beauty and pleasure, and will win the admiration of your family and friends.

Please take the time to read through your Zodiac Owner's Manual. It is set out in such a way that you can see the simple steps to keep your pool or spa in sparkling clean condition.

If you would like to know more about how your new chlorinator works, or about water chemistry matters, you will find that this owner's manual will provide you with useful information.

And don't forget that your chlorinator is backed by a comprehensive warranty. The exclusive Zodiac warranty is an expression of the confidence that Zodiac Group Australia Pty Ltd has in its products, and is your re-assurance of prompt and expert after-sales service by professional technicians.

Thank you again for choosing a Zodiac Saltwater Chlorinator. We wish you many happy years of bathing in your "Zodiac" pool or spa.

For more information talk to your local pool shop or telephone Zodiac Group Australia: 1800 688 552. Due to constant developments and improvements, specifications may change without notice.

INDEX

| | |
|--|-----------|
| How Your Chlorinator Works | 1 |
| Zodiac LM Series Operation | 2 |
| Control Panel Functions | 3 |
| Automatic Operation | 4 |
| Indicator Lights: What They Mean | 6 |
| How To Clean Your Cell | 8 |
| Operating Hints | 9 |
| Salt: When And How To Add It | 10 |
| Some Tips On Water Chemistry | 12 |
| Troubleshooting | 13 |
| Notes | 18 |
| Safety Instructions | 19 |
| Caution | 20 |
| Zodiac LM Series Limited Warranty | 21 |

HOW YOUR CHLORINATOR WORKS

Common salt (sodium chloride) is made up of two elements, sodium and chloride. When your Zodiac LM Series Saltwater Chlorinator is installed, a measured quantity of salt is dissolved in the pool water to make it slightly salty. As part of the daily filtration cycle, the pool water is passed through the Zodiac electrolysis cell to produce chlorine which is dissolved instantly into the water. Your Zodiac Saltwater Chlorinator also produces ozone in the cell as a by-product.

In simple, non-technical terms, the chlorine instantly starts to destroy bacteria, viruses and algae, and in doing this reverts to dissolved salt. This cycle continues with more new chlorine being produced from the salt water in the electrolysis cell, sanitising the pool, and changing once more back to dissolved salt.

Everyday, when the Zodiac LM Series unit and the filtration system are switched on, dust and debris are trapped by the filter and the chlorinator sanitises the water to make it safe and sparkling clean.

Important.

To ensure your Zodiac LM Series works at maximum efficiency, regularly check and maintain the chemistry of your pool.

Preferred Water Chemistry Readings

| | |
|-------------------------------------|--|
| Salt concentration | 4,000 ppm |
| pH | 7.2 to 7.6 |
| Chlorine stabiliser (Cyanuric acid) | 40 to 80 ppm Up to 100 ppm in hotter climates |
| Total alkalinity | 80 to 120 ppm |
| Total hardness | less than 400 ppm |
| Free chlorine | 1 to 3 ppm |

ZODIAC LM SERIES OPERATION

The chlorine production of the Zodiac LM Series is controlled by the number of hours the LM Series and filtration system is ON, as well as the setting of the output control.

For convenience the LM Series and filtration system can be operated automatically through the LM Series timeswitch. (Timeswitch models only)

An added feature of your Zodiac LM Series is the Super Chlorinate function which automatically Super Chlorinates the pool over a 24 hour period.

Your LM Series is also fitted with 3 indicator lights that monitor the operation of the chlorinator and the concentration of salt in the pool.

The LM Series is designed to require minimum operator maintenance and uses reverse polarity technology to minimise the scaling of the cell.

Models not fitted with timeswitch.

Power to these units may be controlled by the external filtration system timer.

The chlorinator functions may only be set when the filtration system is running.

The Super Chlorinate mode will increase the output for the next 24 hours of running time. To use the Super Chlorinate mode effectively, the filtration system should be run continuously for 24 hours.

A pump output socket is provided on the Zodiac LM Series rear panel, if this socket is used the pump would be switched ON/OFF with the chlorinator front panel ON/OFF button.

Output Button.

The output button is used to set the chlorine output of the Zodiac LM Series.

Chlorine output is selected by repeatedly pushing this button until maximum is reached on the chlorine output indicator. An extra push of this button will reset the output to minimum.

On/Off Button.

This button over-rides any automatic internal time switch setting and switches the LM Series and filtration system ON and OFF.

The function is helpful for checking and/or altering the chlorine output settings and other maintenance tasks. Operation of the ON/OFF button will not change the timeswitch settings. In fact the Zodiac LM Series is so smart, it will switch itself back to automatic for you.

Super Chlorinate Button.

The Super Chlorinate function is used to rapidly add chlorine to the pool.

A detailed explanation of the Super Chlorinate function is given in the Automatic Operation section of this manual.

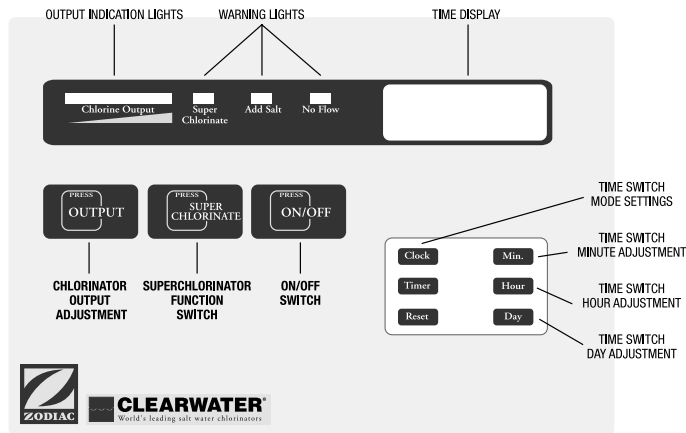

LM Display Panel

Timeswitch (where fitted, “LM2-TS” model only).

Initially the timeswitch display may be blank. Once mains power is applied the internal backup battery will only take a few seconds to charge enough for the display to turn on.

All the timeswitch settings can be cancelled by using the Reset button. This will leave the clock display flashing. Pressing the Clock button will stop the display flashing, the following procedure for setting the clock can then be followed.

Please note: High ambient temperatures may cause the clock display to temporarily go black. Normal readings will return when the temperature drops.

Setting the Clock.

1. Push and HOLD the Clock button.
2. Press the Min. button to increment the minutes.
3. Press the Hour button to increment the hours. Note the hours are displayed in 24 hour format.
4. Press the Day button to increment the day.
5. When you have finished setting the clock release the Clock button.

Setting the Timer for automatic operation.

To set the ON/OFF time.

1. Press the Timer button to step through to the timer setting you wish to set, 1 ON, 1 OFF, 2 ON6 OFF. You must set an OFF time for each ON time.
2. Press the Min. button to set the minutes.
3. Press the Hour button to set the hours.

NOTE: If the “Day” display is not showing, the times will be the same for all days and you need not continue further.

If you wish to set the timer for different times on different days then continue on. Press the **Day** button to step through the days.

MO,TU,WE,TH,FR,SA and SU – to set a different times on each day of the week.

“MO,TU,WE,TH,FR” – to set the same times from Monday to Friday.

“SA,SU” – to set the same times on Saturday and Sunday.

“MO,TU,WE,TH,FR,SA” – to set the same times from Monday to Saturday.

AUTOMATIC OPERATION

The next press of the Day button will turn off the **MO, TU, WE, TH, FR, SA, SU** display (no day display showing), in this mode the timer operates at the same times on every day. This is the normal setting.

NOTE: Pressing the Clock button will get you out of timer set mode, or after a few minutes the timeswitch will automatically revert back to the clock mode. It is possible to have your filtration and Zodiac LM Series operate up to 6 different times per day. It is not necessary to use all 6 on/off timer settings. If you do not wish to use separate settings for individual days, ensure that the on/off settings are clear to avoid unwanted on/off times.

Chlorine Output Setting.

Chlorine production is controlled by both the number of hours of ON time set on the timeswitch above and by controlling the chlorine output via the front panel output adjustment. Repeated pushing of the Output button increases the chlorine production one step at a time until maximum is reached. An extra push of this adjustment at maximum resets the output to minimum.

Use of the ON/OFF control on the front panel overrides the timeswitch settings to switch the chlorinator and the connected pump ON or OFF. This function is helpful for checking and altering the chlorine production settings, and other maintenance tasks. The normal timer settings are not changed by this process and will resume at the pre-set time.

Super Chlorinate.

The Super Chlorinate function is used to rapidly add chlorine to the pool. When pressed, the timer and chlorine output settings are temporarily over-ridden and the chlorinator is set to run for approx. 24 hours at increased chlorine production. To disable this process press the Super Chlorinate switch a second time. Normal timer operation and output settings resume at the conclusion of the pre-set Super Chlorinate period. See 'Problems you may encounter' parts B & C for details regarding when the Super Chlorinate function should be used.

NOTE: During Super Chlorinate startup the chlorinator may actually switch the cell off for a few minutes as the cell is prepared for the following 24 hours operation.

If this happens the yellow minimum output light will flash.

Backup Battery.

The Zodiac LM Series is fitted with a rechargeable battery. If the power is removed, the LM Series will retain the timeswitch settings, output power settings, and Super Chlorinate settings.

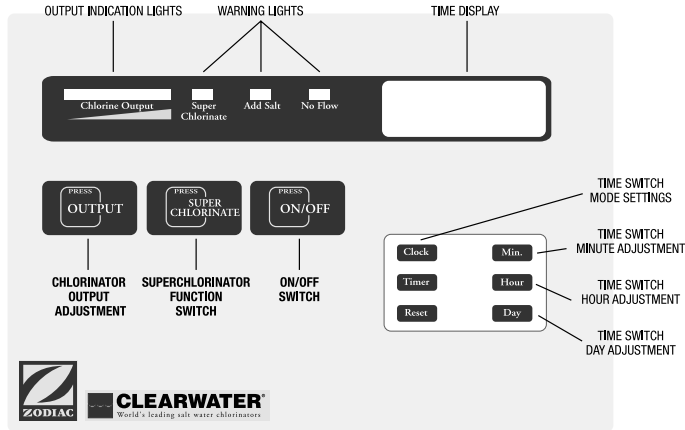

LM Display Panel

Chlorine Output.

A series of six lights indicate the chlorine output setting of the power pack. More lights equals greater chlorine production. **Note:** This setting does not show the actual chlorine reading in the pool, use of a test kit is required to confirm the Free Chlorine reading of the pool water.

Chlorine Output - Yellow Light Flashing.

The yellow (low output) light flashes for a few minutes during cell reversal (cell self clean) indicating no output during this time.

Super Chlorinate - Light ON.

This light indicates that the Super Chlorinate feature has been selected, it will turn OFF when the Super Chlorinate period has ended.

Super Chlorinate - Light OFF.

Function not selected.

Add Salt - Light ON.

The Add Salt light will come on at any salt level between 3000ppm and 4000ppm depending on mains voltage and water temperature. This is not a fault but a precaution to ensure the salt level is never too low. (See 'Salt: When And How To Add It').

Note: Operating the Zodiac LM Series at reduced salt levels may shorten the life of the cell.

Add Salt - Light OFF.

Indicates that the salt level in the pool is correct.

No Flow - Light ON.

This indicates insufficient water flow in cell, usually caused by the pump not running. The chlorine output will also turn off at this time.

All Lights OFF.

All lights OFF indicates the LM is turned off. Check if the time clock indicates ON or OFF, or the mains power is disconnected. Check the mains power circuit breaker.

HOW TO CLEAN YOUR CELL.

Global experience has shown that on rare occasions in some places as a result of very 'hard' water, the self cleaning electrodes may benefit from occasional manual cleaning.

1. Switch off the filter pump and chlorinator, close necessary valves.
2. Unplug the leads from the cell terminals.
3. Undo the two barrel unions joining the cell housing to the pool filtration system and carefully remove the cell housing. Lay the housing upside down on a flat surface with the inlet ports on top.
Note: The use of eye protection is recommended when working with pool chemicals.
5. Pour the cleaning mixture into the upturned cell housing until the electrodes are completely covered. You can purchase cell cleaning solution from a pool shop, or mix your own in a suitable plastic vessel by adding one (1) part of Hydrochloric (Muriatic) acid to ten (10) parts water. Allow the cleaning solution to dissolve the calcium deposits for about 10 minutes.

HOW TO CLEAN YOUR CELL

When the electrodes are clean, pour the cleaning solution and the calcium residue out of the cell housing into a bucket of water; this can now be disposed of down a drain. Note that the solution is now near neutral pH and is environmental friendly.

6. Repeat the procedure if necessary. Take care to avoid splashing the cell terminals and other equipment with the acidic cleaning solution. Wash down any spills with plenty of fresh water.
7. Rinse the electrodes in clean water and refit the cell and housing to the filtration system. Tighten the barrel union connections to prevent leaks.
8. Replace the electrical connectors after drying and smearing lightly with silicone grease.
9. Reset valves and switches. Turn pump and chlorinator on.
10. Confirm chlorine output and settings on the power pack. Timer settings are automatically retained.

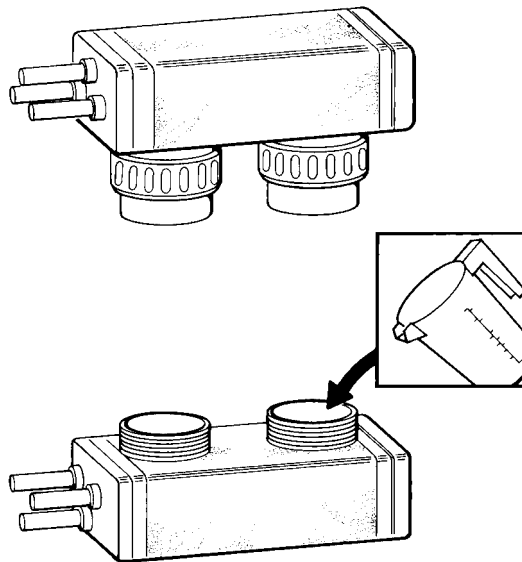

Chlorinator Maintenance

Damage caused by insects.

The case of the Zodiac power pack has small vents to allow internal components to remain cool in hot weather. Sometimes small insects may enter the case of the power pack, and this can cause damage to the internal electrical components. To avoid this, spray some insect repellent on surfaces around the power pack.

A. Filtration and chlorination system operating periods.

The Zodiac LM Series chlorinator has an inbuilt timeswitch (where fitted) to automatically switch the filtration and chlorination system ON and OFF, up to six times a day. Run your filtration and chlorination system for at least 6 to 8 hours per day. For best efficiency, operate the system in the cool hours of the evening, or the early morning. During very hot weather it might be necessary to run the system for around 10 hours per day, but in winter, it is only necessary to run the filtration system for around 4 hours per day. Shorter periods will help to lengthen the life of the cell electrodes.

B. Chlorine output settings.

Commence operation of the Zodiac LM Series at maximum output. Add salt to the pool if the 'Add Salt' light is showing.

For a home pool of about 50,000 litres, the addition of one 25Kg bag of salt will increase the salt concentration by 500 ppm, see 'Salt: When And How To Add It'.

C. Free (residual) chlorine reading.

The free chlorine residual in the pool should be around 1-3 ppm. Increasing the daily operating period of the system increases the free chlorine reading, and a shorter operating period reduces the chlorine reading.

Likewise, operating the chlorinator at maximum output will produce a higher chlorine reading than operating the chlorinator at a lower setting of say, 50%.

D. Chlorine stabiliser (Cyanuric acid) level.

Make sure that the water has a satisfactory chlorine stabiliser (Cyanuric acid) reading which is within the band of 40 - 80 ppm. Chlorine stabiliser helps to keep a satisfactory free chlorine reading in hot sunny climates.

E. pH readings.

It is ABSOLUTELY ESSENTIAL that the pH of the pool be maintained in the range of 7.2 - 7.6 (for fibreglass pools, as low as 7.0).

The effectiveness of chlorine as a sanitiser is significantly reduced as the pH rises. At a pH of 8.0, nearly all of the chlorine being added to the pool is wasted, and it will be almost impossible to maintain a satisfactory free chlorine reading.

F. Regular maintenance checks.

Weekly:

- Visually check the cell electrodes. Remove any debris that may have passed through the filter and lodged in the cell housing. Take care not to scratch or bend the cell plates. (see 'Chlorinator maintenance').
- Check the free chlorine.
- Check the pH of the water. Adjust if necessary.
- Check the pressure gauge on the filter to see if backwashing is necessary.

Monthly:

- Check the salt concentration of the pool (see 'Salt:When And How To Add It).
- Check the total alkalinity. Adjust if necessary.
- Check the chlorine stabiliser reading. Adjust if necessary.

WHEN TO ADD SALT.

Add salt when indicated on the control panel. The light marked 'Add Salt' functions automatically when extra salt is needed. Note that the 'Add Salt' light may switch on at any salt level between 3000 and 4000ppm, depending upon the water temperature and mains voltage (see note). This is not a fault but a precaution to ensure that the salt level is never too low.

The salt concentration should normally be around 4000 ppm, but should never be allowed to fall below 3000 ppm, as this can reduce the life of the cell electrodes. Salt is not lost through evaporation. Salt is lost with the water splashed out of the pool or during backwash. Adding fresh water to the pool dilutes the salt concentration. A top-up of salt is needed from time to time, just before and just after summer are the best times.

SALT: WHEN & HOW TO ADD IT

NOTE: Even if the salt concentration is around 4000ppm, the Add Salt light may switch ON if the water temperature or mains supply voltage are too low. In this situation, it may not be possible to set the Chlorine Output to maximum. Addition of more salt to the pool will allow the Chlorine Output to reach maximum settings.

How much to add.

Use only refined salt (sodium chloride) when adding salt to the water of your pool. For home pools of about 50,000 litres eight 25Kg bags of salt are required to reach 4000 ppm concentration, each additional 25Kg bag of salt will increase the salt reading by about 500 ppm. Larger pools require greater amounts of salt to be added. Add enough salt to obtain a salt concentration of 4000 ppm.

Note: ppm (parts per million) is sometimes referred to as mg/l (milligrams per litre).

How to add salt.

When the control panel indicates “add salt”, empty the contents of no more than two 25Kg (50lb) bags of salt at one time into the shallow end of the pool. The salt will slowly drift down to the deep end, helping to disperse the salt. Do not add the salt to the skimmer box.

Run the filter for 4 to 6 hours to help disperse the salt around the pool.

Note: allow 24 hours for the salt to fully dissolve.

Observe the chlorinator control panel and confirm the ‘Add Salt’ light is not showing. If the light remains on, wait 24 hours and repeat the procedure with a further two bags of refined salt. The ‘Add Salt’ light should now be off. If not (the light is still glowing) the cell should be checked to confirm it is functioning correctly. Please contact your Zodiac service technician or your pool shop to have the cell tested.

SOME TIPS ON WATER CHEMISTRY

pH is very important.

Do not confuse pH with total alkalinity. pH is a simple numerical scale which expresses the acid/alkaline balance of the water. A pH value of 7.0 denotes neutrality, ie. neither acid nor alkaline. High pH values (ie. above 7.0) denote alkaline conditions. Low pH values (below 7.0) denote acidic conditions.

How to adjust pH.

Aim for a pH range of 7.2 - 7.6 which is ideal for maximum comfort and minimum chlorine demand. Always adjust total alkalinity before adjusting pH.

Low pH (acidic water) leads to stinging eyes and corrosion of open metal fittings. Raise the pH by adding sodium bicarbonate, soda ash, or dry alkali. First pre-dissolve in water, then add no more than 500 grams at a time. Check the pH after each addition is thoroughly dispersed.

High pH (alkaline water) leads to clouding of the water and prevents the sterilising action of chlorine. This means algae and germs can grow. Lower the pH by adding hydrochloric acid to the pool water. The acid demand indicated by your 4-in-1 test kit will show the amount of acid to use (or check with your pool retailer).

If you have the problem of never being able to keep the pH right, check your total alkalinity.

Total alkalinity affects pH.

Total alkalinity is a measure of the alkaline chemicals in your pool water (eg. Bicarbonates, carbonates, and hydroxides). It can be thought of as the buffering system necessary to control pH. Low alkalinity can be compared to weak shock absorbers on a car, the pH will go up and down like a perpetual yoyo. pH will be difficult to adjust and staining of pool surfaces may occur when total alkalinity is too low.

Total alkalinity should be in the range of 80 - 120 ppm. Total alkalinity is often confused with pH, which it affects.

To raise total alkalinity, add pH buffer (also called pH stabiliser or sodium bicarbonate) at the rate shown in the manufacturers instructions. A small amount is added daily to achieve a total alkalinity reading of 80 - 120 ppm. If total alkalinity is too high, scale will tend to form in the chlorinator cell, on pool walls, and in the heat-exchanger of your heater.

To lower the total alkalinity, add 400 ml hydrochloric acid each day until a total alkalinity reading taken at least 24 hours later is in the range 80 - 120 ppm. When the total alkalinity is finally correct you may need to adjust the pH.

NOTE: If the chlorinator and pump are running it is normal for a cloud of small bubbles to be produced in the cell, indicating chlorine is also being produced.

Problem A

Water looks clean but no chlorine residual reading.

To test for chlorine residual, switch on the filtration system and adjust the Zodiac LM Series to maximum output. After a few minutes take a water sample from the pool. Test this water with your test kit. A minimum chlorine residual of 1 - 3 ppm is desirable.

REMEDY:

- Adjust the pH within the range 7.2 - 7.6.
- Make sure your cell is clean.
- Check cyanuric acid levels.
- Increase the setting of the output control.
- Adjust total alkalinity to recommended range.
- Increase the running time of the filter and chlorinator. Make sure that the filter is clean and functioning properly.
- Add salt if indicated by 'Add Salt' light.

Use chlorine stabiliser (cyanuric acid) to protect chlorine residual.

This chemical acts as a sun-screen for chlorine and prevents chlorine being too quickly destroyed by the sun. Chlorine stabiliser is essential to prolong the life of chlorine in the pool water. It should be added following the manufacturer's instructions to achieve a level of 40 - 80 ppm. This will probably be about 40 - 80g for every 1,000 litres of water. Take care that chlorine stabiliser levels do not exceed 80 ppm.

Copper based algaecides.

It can sometimes happen that some copper based algaecides catalyse (break down) chlorine in a pool. This can produce the apparent contradiction that there is no chlorine residual reading, but there is no sign of the pool water going green because of algae. The explanation is that the copper based algaecide is controlling the algae, but breaking down the chlorine to unmeasurable levels. Usually, over a period of time, the effect of the copper will diminish and the chlorine residual reading will reappear.

Problem B

Pool green and no chlorine reading.

Chlorine is still considered the most effective way of destroying algae and bacteria in your pool water. A chlorine residual of 1 to 3 ppm is considered desirable. However, there are some types of harmful micro-organisms and algae which develop an immunity to these low levels of chlorine.

REMEDY: Superchlorinate or shock dosing, especially in hot weather, is the remedy. This procedure raises the chlorine residual to a very high level for a short period of time, and reduces chlorine demand.

I. Superchlorinating with a Clearwater chlorinator:

- i) Backwash the filter.
- ii) Adjust the pH to within the range 7.2 - 7.6.
- iii) Press the button marked 'Super Chlorinate'. The Zodiac LM Series automatically increases its output and runs for approx. 24 hours uninterrupted. The internal timer controls the Zodiac LM Series and the filter pump during this period, returning to the original timer settings when the superchlorinate function is complete.
- iv) After 24 hours, backwash the filter.
- v) Re-adjust the pH to 7.2 - 7.6.
- vi) Check the chlorine reading.
- vii) If the chlorine reading is too low, repeat steps (iii) to (vi) until the chlorine reading is satisfactory.

2. Shock dosing with chlorine or oxidising agents:

- i) Backwash the filter.
- ii) Adjust the pH to within the range 7.2 - 7.6.
- iii) Add 110ml of liquid chlorine for every 1000 litres or add any suitable oxidising agent at the rate recommended by the manufacturer or your pool shop.

When shock dosing, it is most important to add all the chlorine in one dose. If in doubt, or if the problem is severe, use more rather than less, all in one dose.

- iv) After shock dosing, re-adjust the pH to within the range of 7.2 - 7.6 and check the chlorine level before using the pool. Up to 5ppm is not harmful.

Problem C

Chlorine odour.

CAUSE: Not enough free chlorine.

Surprisingly, the problem here is not too much chlorine as many imagine. Chloramines form by the bonding of chlorine with amines from sweat, urine and other sources. These chloramines make the chlorine odour and can also cause eye and skin irritation. Free chlorine does not smell (up to 10 ppm concentration).

REMEDY: Same as problem B.

Problem D

Slimy walls of pool or spa.

CAUSE: Combined algae and bacteria growth.

REMEDY: Scrub down the affected walls and follow remedy as for Problem B, using a large shock dose of chlorine.

Problem E

Eye and/or skin irritation.

CAUSE: Incorrect pH levels of chloramines.

REMEDY: Adjust the pH to within the range 7.2 - 7.6. If the problem continues, follow the remedy Problem B.

Problem F

Scale formation on pool equipment.

To clean the deposit (scale) from the cell, see Chlorinator Maintenance section.

CAUSE 1: Incorrect pH and hard water.

REMEDY: Adjust the pH to within the range 7.2 - 7.6.

CAUSE 2: High total alkalinity.

REMEDY: Adjust the total alkalinity to within the range 80 - 120 ppm.

Problem G

Chlorine Output will not reach maximum - Add Salt light may also be on.

CAUSE 1: Salt level below 4000ppm or water very cold.

REMEDY: Add salt. (See Salt: When and How to Add it)

CAUSE 2: Cell reversing (self clean).

REMEDY: If the cell is reversing, the yellow light on the Chlorine Output indicator will flash, wait around three minutes and the output should return to normal.

CAUSE 3: Cell electrodes may be damaged.

REMEDY: Replace cell. The cell must be replaced with the same model or the chlorinator will not function correctly, see Zodiac or a Zodiac Service Centre.

Problem H

No Flow light on.

CAUSE 1: Insufficient water flow through the cell.

REMEDY: Ensure sufficient water flow through chlorinator cell. Is the filter-pump on? Is the flow restricted because the filter needs backwashing? Look for a pocket of air trapped in the top of the cell, this would confirm one of the problems just mentioned, eg. low water flow through the cell.

CAUSE 2: Sensor disconnected.

REMEDY: Make sure that the sensor lead from the power pack to the cell is attached at the cell (small clip lead).

Problem I

Chlorinator stops working, all lights OFF.

CAUSE: Unit turned off.

REMEDY: Push ON/OFF button and check ON - OFF indicator on time switch.

CAUSE 2: Mains power removed or blown fuse/circuit breaker off.

REMEDY: Check mains power source, check fuse/circuit breaker is on.

Replacing the Fuse.

Switch off and disconnect the Zodiac LM Series from the mains power. An on board mains fuse/circuit breaker is located in the bottom rear of the LM Series next to the power cord. Check and if necessary replace with a 2 Amp 5x20mm fuse/reset circuit breaker.

Reconnect the LM Series to mains power and switch on. If the fuse continues to blow, this indicates a serious fault, switch off the power, disconnect the LM Series and contact Zodiac or a Zodiac service centre for further advice.

Mains power supply.

Your Zodiac Saltwater chlorinator must be connected to a properly earthed (grounded) electrical power socket, or power source.

IMPORTANT SAFETY INSTRUCTIONS

When installing and using this electrical equipment, basic safety precautions should always be followed, including the following:

1. READ AND FOLLOW ALL INSTRUCTIONS.

2. **WARNING** - To reduce the risk of injury, do not permit children to use this product unless they are closely supervised at all times.
3. Do not bury cord. Locate cord to minimise abuse from lawn mowers, hedge trimmers and other equipment.
4. **WARNING** - To reduce the risk of electrical shock, replace damaged cord immediately.

5. SAVE THESE INSTRUCTIONS

CAUTION

Failure to observe the following could invalidate your warranty and damage pool equipment.

1. Chlorinator must be installed and operated as specified.
2. Your Zodiac Saltwater Chlorinator has been fitted with an electronic flow switch. This device automatically switches the chlorinator 'OFF' when the water through the cell stops. Do not in any way interfere with this system which has been fitted for your protection.
3. Do not scratch or bend the plates in the cell housing.
4. Power to the Zodiac LM Series should be turned off before unplugging the cell connectors.
5. Keep the cell terminals protected with a light smear of silicone grease, use of other than silicone grease may damage the terminal seals and 'O' rings. Do not immerse these terminals in acid wash solution, and avoid accidental contact with salt water.
6. Water above the temperature of 40 degrees Celsius must not flow through the cell.
7. Water pressure in the cell must not exceed 200kPa.
8. Check the cell frequently to prevent the accumulation of pool debris that for any reason may have by-passed the pool filter. Particularly after backwashing.
9. Power pack must not be installed directly above any other heat source such as filter pump or heater. It must be at least 300mm from the ground to allow free circulation of air around it. It must not be enclosed in a closed box. If the power pack is to be installed on a post then it must be centrally positioned on a flat panel of suitable waterproof material at least 350mm wide and 250mm high. As for all electronic equipment the power pack life will be increased if it is mounted in a shady spot and not in direct sunlight.
10. Never plug more than one pump at a time into the 3-pin socket (where fitted) in the base of the power supply.

ZODIAC LM SERIES LIMITED WARRANTY

Your Zodiac Saltwater Chlorinator has been manufactured with the greatest of care and from the best available materials. The warranty period begins on the date of the manufacture according to the serial number on the product, unless proof of purchase date is supplied, or the warranty has been registered with us. Refer also to the section titled "Caution" in the Owner's Manual. This warranty will be void if parts other than Zodiac approved parts are used for repairs.

Chlorinator (excluding cell electrodes) Warranty

The manufacturer warrants for a period of 2 years from the date of purchase, defects found to be due solely to faulty materials or workmanship. It will repair or replace at its option such faulty materials or parts free of charge.

Cell Electrode Warranty

The cell electrodes and their special coatings are covered by a 1-year full warranty. In addition to the 1-year full warranty, the manufacturer warrants the products for a subsequent 2-year period, pro-rated over the three years.

The cost of field service calls, or of freight back for repairs are not covered by the warranty. The Zodiac warranty is transferable and protects the original purchaser and subsequent owners of the product. Proof of purchase or registration of the warranty with Zodiac Group Australia Pty Ltd must be provided by the owner to support any warranty claim.

This pro-rata warranty is offered by Zodiac directly to the chlorinator end-user and requires that person to deal directly with Zodiac Group Australia Pty Ltd.

***The warranty applicable to commercial application is limited to 12 months from the date of installation.**

Don't forget to complete your purchase details on the inside back cover of this warranty and return the Reply Paid Warranty Registration to Zodiac Group Australia Pty Ltd.

Thank you for choosing this product from Zodiac Group Australia and we wish you many happy years of bathing in your 'Zodiac' pool or spa.

This warranty card will remain the property of Zodiac Group Australia Pty Ltd.

This warranty is not valid outside of Australia and New Zealand.

For more information talk to your local pool shop or telephone Zodiac Group Australia: 1800 688 552
or access our webpage: www.zodiac.com.au.

Due to constant developments and improvements, specifications may change without notice.