



Residential



Agricultural



Process

onga®

Owner's Manual



PPP Pool Pump Range

Should the installer or owner be unfamiliar with the correct installation or operation of this type of equipment you should contact the distributor/manufacturer for the correct advice before proceeding with the installation or operation of the product.
An earth leakage or residual current protection device must be fitted to all installations.



Pentair Water

Australia

Freecall 1800 664 266 Web: onga.com.au
Email: sales@onga.com.au Fax: 1800 006 688

New Zealand

Freecall 0800 664 269 Web: onga.co.nz
Email: query@onga.co.nz Auckland Fax: +64 9 579 6497
Christchurch Fax: +64 3 343 1054

Export Sales

Email: export@onga.com.au Tel: +61 3 9574 4000
Fax: +61 3 9574 4090

Germany

Sta-Rite Industries GmbH Europa

Tel: +49 6155 8417-0 Web: starite.de
Email: info@starite.de Fax: +49 6155 8417-99

Onga Pty Ltd ABN 27 004 856 204

Disclaimer Every endeavour has been made to publish the correct details in this Price List. No responsibility will be taken for errors, omissions or changes in product specifications.



AUSTRALIAN MANUFACTURER AND PROUD OF IT



L300086-1104

Relax - you've bought an Onga ...

Congratulations on your decision to purchase an Onga product. Onga is one of the best known brands in its field, with a proud local and International reputation.

Onga is a brand for reliability, value for money and technological innovation.

You will find Onga product wherever people need to move water in 3 broad markets covering:



Residential

Technologically advanced solutions for moving and treating water in the Home, Garden, Pool and Spa.



Agricultural

Innovative Stock and Crop water management solutions for Primary Industries.



Process

Water movement products for Building services, Emergency services and Original Equipment manufacturers.

How to get service:

In Australia please contact 1800 664 266 In New Zealand please contact 0800 664 269

Claims under this warranty must give evidence of date of purchase, model and serial number of the product and the claimants name, address and telephone number.

- 1) To obtain warranted service, you will be required to provide to either Onga state office or recommended service agent:-
 - a) the product;
 - b) confirmation in writing specifying the nature of your claim;
 - c) proof providing date of original purchase;
 - d) full contact details including name and address;
 - e) the serial number of the product if any.
- 2) The product is to be forwarded by the customer freight paid to an Authorised Onga service agent. Infield service by an authorised Onga Service Agent will incur a travel, removal & reinstallation fee to adjudicate on warranty issues. Authorised warranty will be free of charge for the first 12 month period from date of the first consumer purchase.
- 3) Warranty service work will be denied or suspended, on equipment not readily accessible to service personnel, that is products that are behind barriers, tiled or bricked in, installed in roofs or second story external walls including inaccessible power points.
- 4) Any service of any product which is found to be faulty due to abuse, fair wear & tear, misuse or improper installation will be charged to the owner at the service agents current servicing hourly rate.

Limitation of implied warranties:

THERE ARE NO WARRANTIES, EXPRESSED OR IMPLIED, WHICH EXTEND BEYOND THE DESCRIPTION CONTAINED HEREIN INCLUDING THE IMPLIED WARRANTY OF MERCHANTABILITY AND FITNESS FOR A PARTICULAR PURPOSE.

Exclusion of damages:

ONGA'S LIABILITY IS LIMITED TO THE COST OF REPAIR OR REPLACEMENT OF THE PRODUCT. ONGA SHALL NOT BE LIABLE FOR:

- 1) DAMAGE TO OTHER PROPERTY CAUSED BY ANY DEFECTS IN THE PRODUCT, DAMAGES BASED UPON INCONVENIENCE, LOSS OF USE OF THE PRODUCT, LOSS OF TIME, LOSS OF PROFITS, LOSS OF BUSINESS OPPORTUNITY, LOSS OF GOODWILL, INTERFERENCE OF BUSINESS RELATIONSHIPS, OR OTHER COMMERCIAL LOSS, EVEN IF ADVISED OF THE POSSIBILITY OF SUCH DAMAGE.
- 2) ANY OTHER DAMAGES, WHETHER INCIDENTAL, CONSEQUENTIAL OR OTHERWISE.
- 3) ANY CLAIM AGAINST THE CUSTOMER BY ANY OTHER PARTY.

Effective law:

This warranty gives you specific legal rights, and you may also have other rights which vary from state to state. Nothing in this warranty limits or restricts, or is intended to derogate from, any right or remedy which the purchaser or ultimate user of the product may have pursuant to Australian state and/or Australian federal consumer protection legislation, New Zealand Sale of Goods Act, Consumer Guarantees Act, Fair Trading Act or any other relevant and applicable New Zealand legislation or authority and where necessary shall so be read and construed.

IMPORTANT

Please attach your sales invoice/docket here as proof of purchase should warranty service be required.

Please do not return Warranty - Retain for your records.

Purchased From _____

Purchase Date _____ Serial No _____ Model No _____

Onga warrants that, when this product is used for the purpose it was designed, is correctly housed and vented against weather, vermin, dust etc., that it will be free of material and manufacturing defects at the time of the original purchase.

This warranty is limited to the cost of the product and does not cover third party costs including the costs of electricians, plumbers, etc. unless authorised by Onga pumps.

TERMS AND CONDITIONS APPLICABLE INTERNATIONALLY

- 1) **How long the warranty is effective Internationally**
This Onga product is warranted for 12 months for all parts from the date of the first consumer purchase. Should any parts fail as a result of such defects within the specified period, the part will be replaced free of charge. (This does not include travel charges, removal and reinstallation charges.)

TERMS AND CONDITIONS APPLICABLE IN AUSTRALIA AND NEW ZEALAND

- 1) YOU SHOULD CAREFULLY READ THE INSTRUCTIONS SUPPLIED PRIOR TO USING THIS ONGA PRODUCT.
This product is to be installed and operated in accordance with the instructions provided. This warranty will not apply if it is used in a manner other than in accordance with the instructions.

What the warranty covers:

Onga warrants its products to be free of defects in material and workmanship during the warranty period. If a product proves to be defective in material or workmanship during the warranty period, then Onga will, at its sole option repair or replace the product with a like product. Replacement product or parts may include re-manufactured or refurbished parts or components.

How long the warranty is effective:

- 1) **This Onga product is warranted for 3 years for all parts from the date of the first consumer purchase.**
2) **Where this Onga product is sold for commercial application as defined in the relevant Trade Practices and Consumer Protection legislation the warranty shall be for a period of six months from the date of purchase by the end user.**

Who the warranty protects:

This warranty is valid only for the consumer purchaser.

What the warranty does not cover:

- 1) **Damage, deterioration or malfunction resulting from:**
- a) **accident, misuse, negligence, fire, water, lightning, or other acts of nature, unauthorised product modification or failure to follow instructions supplied with the product;**
 - b) **repair or attempted repair by anyone not authorised by Onga;**
 - c) **any damage to the product due to shipment;**
 - d) **removal or installation of the product;**
 - e) **causes external to the product such as electric power fluctuations or failure;**
 - f) **use of supplies or parts not meeting Onga specifications;**
 - g) **normal wear and tear;**
 - h) **water ingress or exposure to abnormal corrosive conditions or "run dry" conditions;**
 - i) **any other cause which does not relate to a product defect.**
- 2) **Damage caused to the product as a consequence of use of another manufacturer's product used in conjunction with Onga and affiliate companies.**
- 3) **Swimming pools or spa equipment will not be warranted where the Langelier saturation index 'pH' range is outside 7.2 to 7.6 and they have not been regularly treated with chlorine or bromine based sanitising systems, or other recognised sanitising systems.**

Spare Parts:

Spare parts are usually stocked for a reasonable period of time following last production.

Onga does not warrant that spare parts will be made available for the whole of the reasonable period and reserves its right to cease supplying spare parts or providing facilities for repair of spare parts in circumstances which are beyond its control including the requirement to remove spare parts from sale as a consequence of changes in the law or otherwise as it deems fit.

1. Continual Product Improvement

We employ the best engineers both in Australia and around the world to develop new and better ways to take water further.

2. Operational Excellence

There is only one standard that we set ourselves for both product quality and the quality of our service. That standard is excellence... to have no-one better than us at what we do... nothing short of that is acceptable. Our commitment to quality is reinforced with our ISO 9001:2000 accreditation.



3. A Fair Price

Onga products are neither the cheapest nor the most expensive in their field. Our products do, on the other hand, always represent very good value for money - they always have and they always will.

4. Our Team of Dealers

The hand picked authorised Onga dealer network throughout Australia and worldwide are second to none. We invest considerable time and resources training and supporting them through the Onga Training Academy.

ongga[®]
TAKING WATER FURTHER

IMPORTANT!

This manual should be furnished to the end user of this pump. This manual must be read and understood before operation and followed during operation.

These instructions are a guide only. Users not familiar with swimming pool equipment should seek advice from people with experience in pool equipment installation.

Models:

Part number	Description
PPP550	Onga Pool Pump 550 watt (0.75HP)
PPP750	Onga Pool Pump 750 watt (1HP)
PPP1100	Onga Pool Pump 1000 watt (1.25HP)
PPP1500	Onga Pool Pump 1200 watt (1.5HP)
PPP1503	Onga Pool Pump 1200 watt (1.5HP) 3 Phase
PPP1500H	Onga Pool Pump 1500 watt (2HP)

Technical Data

Inlet & Outlet	ABS Barrel union to suit 40mm PVC pipe internal ABS Barrel union to suit 50mm PVC Socket external
Maximum Pump Pressure	195kPa
Maximum Working Pressure	295kPa
Water Temperature Rating	5 – 45°C (In line with Health Authority regulations)
Max. Ambient Temperature	55°C
IP Rating	IP55
Electrical Rating	240 volt single phase are supplied as standard with built in thermal overload protection and are designed to plug directly into a 10 amp domestic power supply to local electrical authority specifications. 415 volt 3 phase motors should be protected with the recommended contactor and thermal overloads in accordance with local electrical authority specifications.
Optimal pH Range	7.2 - 7.8 (Guide Only)

Item	Part Description	Qty.	Item	Part Description	Qty.
1	Motor	1	10	Diffuser	1
2	Base	1	11	Impeller	1
3	Screws - Base	2	12	Separator Plate	1
4	Water Slinger	1	13	Barrel Union Assembly	2
5	Nuts - Casing	4	14	Casing & Bowl	1
6	Yoke	1	15	Hair & Lint Pot Basket	1
7	Screws - Yoke	4	16	O'ring - Lid	1
8	Baffle	1	17	Lid	1
9a	Mechanical Seal	1	18	Screws - Casing	4
9b	O'ring - Casing	1	19	O'ring - Barrel Union	2
9c	Shaft Sleeve Assembly	1	20	Priming Cap	1

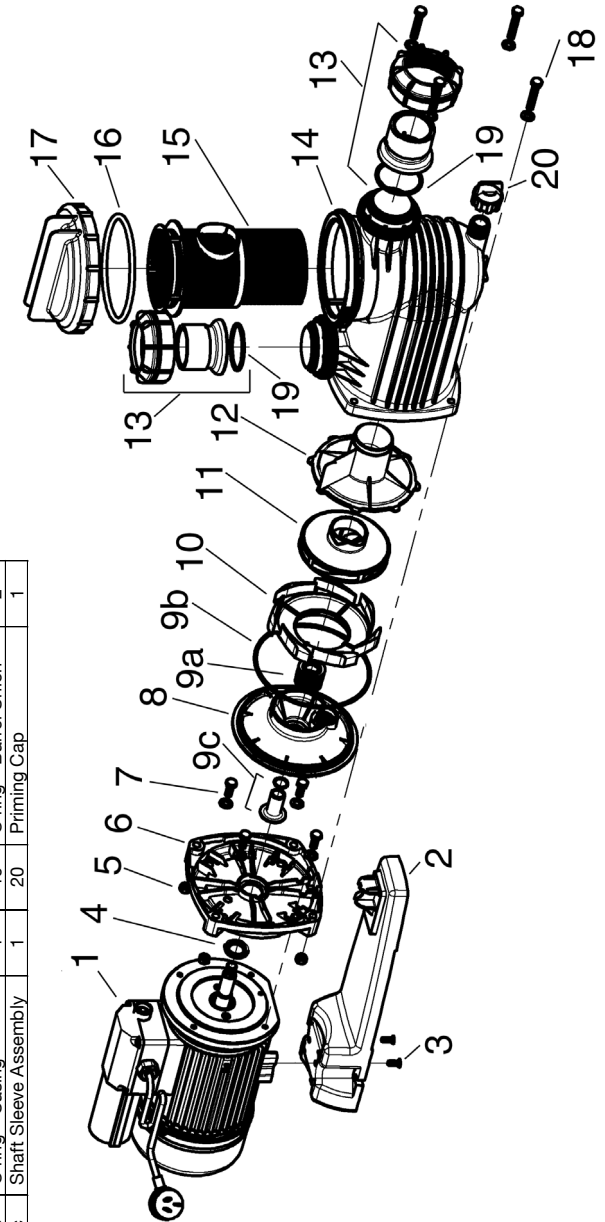

TROUBLE SHOOTING – ALL MODELS

SYMPTOM	CAUSE	REMEDY
Pump does not run	No Power at power point.	Use another known good electrical appliance to check power outlet. Check fuse box / circuit breaker.
	Blown fuse	Check fuse and replace if necessary.
	Automatic thermal overload has tripped to protect the motor.	Switch the power to the pump off and allow the motor to cool before switching back on. Ensure that the pump and motor have adequate ventilation in the area surrounding the pump. Ensure that the pump is not jammed with debris and that the motor shaft spins freely. The motor may be operating on a low voltage supply.
Pump operates with reduced or no flow	Pump is jammed (check if shaft is free to rotate).	Blockage in the pump or suction strainer. Motor bearings may be seized.
	Motor burnt out due to voltage spike or flooded by water.	The motor may need replacing.
	Valves turned to the closed position.	Check the plumbing to ensure the valves are in the correct position for filtering, including any valves on the suction or discharge of the pump.
	Dirty filter.	Clean the filter (refer to the documentation supplied with your filter).
	Air ingress to system.	Re-prime the pump (refer to priming procedure). Check that there are no air leaks in the suction piping or fittings. Ensure the hair & lint pot lid is closed and airtight. Check there are no leaks coming from beneath the pump and casing.
	Lack of water.	Ensure the water level in your pool is at least up to the halfway mark at the skimmer opening.
Pump leaking from between the casing and the motor.	Debris in the pump or skimmer box. (Note: Do not operate the pump without hair & lint pot or skimmer basket correctly fitted).	Ensure that both the hair & lint pot basket and skimmer basket are free of leaves and other debris. Ensure that there is no blockage at the pumps suction or discharge. Ensure that the pump internals are free of foreign matter which may impede the flow of water.
	Casing bolts are not tight. Casing O'ring is worn. Mechanical seal requires replacement.	Switch off pump and loosen the casing bolts. Check alignment and condition of casing O'ring before retightening the bolts. Replace the O'ring if leaking persists. Replace the mechanical seal and lip seal (if fitted).

- Should problems persist, please contact your nearest Onga Service Agent.

Installation

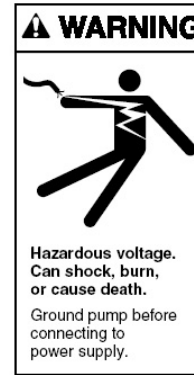

Incorrectly installed or tested equipment may fail, causing severe injury or property damage.

Read and follow instructions in owner's manual when installing and operating equipment. Have a trained pool professional perform all pressure tests.

1. Do not connect system to a high pressure or city water system.
2. Use equipment only in a pool or spa installation.
3. Install pump with at least 2 hydraulically balanced main drains equipped with correctly installed, screw-fastened, anti-entrapment certified covers according to local regulations.
3. Trapped air in system can cause explosion. Ensure all air is out of system before operating or testing equipment.



Fire and burn hazard. Modern motors run at high temperatures. To reduce risk of fire, do not allow leaves, debris, or foreign matter to collect around the pump motor. To avoid burns when handling the motor, let it cool for at least 20 minutes before trying to work on it. A thermal overload switch protects the motor from heat damage during operation.

INSTALLATION (Continued)

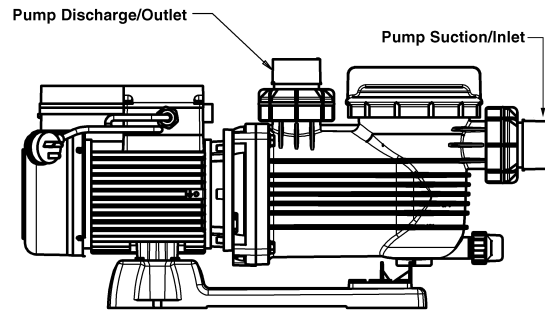

Only qualified, licensed personnel should install pump and wiring whilst observing local safety regulations.

Pump mount must:

Be located away from corrosive or flammable chemicals.

Have enough ventilation to maintain air temperature at less than the maximum ambient temperature rating. If this pump is installed in an enclosure/pump house, the enclosure must have adequate ventilation and air circulation to keep the temperature in the enclosure at or below the motor's rated ambient temperature whenever the pump is running.

Be solid - Level - Rigid - Vibration free. (To reduce vibration and pipe stress, bolt pump to mount).

Allow pump suction inlet height to be as close to water level as possible.

Allow use of short, direct suction pipe (to reduce friction losses).

Allow for shut-off valves in suction and discharge piping.

Have adequate floor drainage to prevent flooding.

Be protected from excess moisture.

Allow adequate access for servicing pump and piping.

Onga recommends mounting the pump on a concrete platform for quietest performance.

NOTICE: For three-phase motor pumps, start the motor for a few revolutions checking that rotation direction is clockwise (watch the motor from the fan side). If rotation is counter-clockwise, change over the connections of two phases.

TROUBLE SHOOTING

If servicing of the unit is required at anytime, a service record should be kept listing details of the problem.

Onga stands by its quality products, however if a fault occurs and cannot be rectified by following the trouble shooting guide as set out below, please contact Onga on **1800 664 266** (Australia) or **0800 664 269** (New Zealand) where our locator service will direct you to your nearest sales stockist or service agent.

Please be aware that a service fee will be applicable if a fault occurs other than that as described in the product guarantee as being due to defects in materials or faulty manufacture.

Pump service should be performed by suitably qualified personnel.

Always unplug power lead prior to service to prevent personal injury.

OPERATION (Continued)

Routine Maintenance

The only routine maintenance required is periodic inspection/cleaning of hair & lint pot basket. Debris or trash that collects in basket will choke off water flow through the pump. Follow instructions below to clean basket:

1. Switch off power to pump, close valves in suction and discharge, and **release all pressure from system before proceeding.**
2. Remove lid (turn counterclockwise). If necessary, undo drain plug to reduce lid vacuum. **Do not** use a hammer or similar tool to loosen the lid. If the lid is too tight to undo by hand, use a lever such as a board or long screwdriver positioned between the lid lugs and turn counterclockwise.
3. Remove basket and clean. Ensure all holes in basket are clear, flush basket with water and replace in bowl assembly with large opening at pipe connection port (between ribs provided). If basket is replaced backwards the lid will not fit on casing & bowl. To clean transparent cover, use water and neutral soap only. Do not use solvents.
4. Clean and inspect lid o'ring; reinstall on bowl assembly.
5. Clean O'ring groove on bowl assembly and replace lid. To help keep cover from sticking, tighten **hand tight only.**
6. Prime pump (refer priming instructions).

Pump Service



Pump should only be serviced by qualified personnel. For best results, use only genuine Onga factory parts. Be sure to prime pump before starting.

Before removing hair & lint pot lid:

1. **SWITCH OFF POWER to pump before proceeding.**
2. **CLOSE SHUT-OFF VALVES in suction and discharge pipes.**
3. **RELEASE ALL PRESSURE from pump and piping system.**
4. **NEVER tighten or loosen lid while pump is operating!**

To avoid dangerous or fatal electrical shock hazard, turn OFF power to motor and remove plug from power outlet before working on pump or motor.

No lubrication or regular maintenance is needed beyond reasonable care and periodic cleaning of strainer basket. When pump is not in use and there is a risk of frost, empty it completely through the drain plug.

Installation (Continued)

NOTICE: If the pump is not provided with a supply cord and a plug, or with other means of disconnection from the supply having a contact separation of at least 3mm in all poles, such means for disconnection must be incorporated in the fixed wiring.

NOTICE: Use Teflon tape for making all threaded connections to the pump. Do not use pipe dope (glue) as this will cause stress fractures in the pump.

Teflon Taping Instructions:

Use only new or clean PVC pipe fittings.

Wrap male pipe threads with one to two layers (or a sufficient number of layers) of Teflon tape. Cover entire threaded portion.

If leaks occur, remove pipe, clean off old tape, rewrap as previously with one to two additional layers of tape and remake the connection.

NOTICE: Support all piping connected with pump.

Piping:

To reduce friction losses use at least 2" (50mm) PVC pipe. Increase size if a long run is needed.

To avoid stress on the pump, support both suction and discharge pipes independently. Place these supports as close to the pump as possible.

To avoid a strain left by a gap at the last connection, start all piping at the pump and run pipe **away** from the pump.

Never use a suction pipe smaller than pump suction connection.

To avoid airlocking, slope suction pipe slightly upward toward the pump.

NOTICE: To prevent flooding when removing pump for service, all flooded suction systems **must** have shut-off valves in suction and discharge pipes.

Fittings:

Fittings restrict flow; for best efficiency use fewest possible fittings.

Avoid fittings which could cause an air trap.

Pool outlets:

Use only non-entrapping suction fittings or double suction conforming with the AS1926.3-2003 Standard, or local authority requirements.



The fittings on these pool pumps are constructed of ABS. Some PVC jointing compounds are incompatible with ABS possibly causing failure to the product. Check compound suitability prior to use.

INSTALLATION (Continued)



All glued fittings and pipe work should be allowed to dry to atmosphere for 24 hours before closing installation. Failure to do so could cause injury or installation failure.



Barrel Unions are to be hand tightened ONLY, to prevent damage occurring from over-tightening.

Pump Mounting:

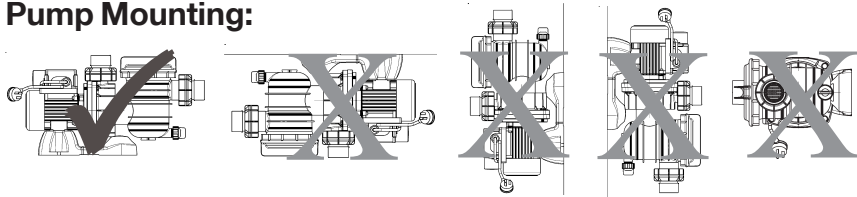

- 1) Pump position must be: Solid - Level - Rigid - Vibration Free
- 2) Allow pump suction inlet height to be as close to water level as possible.
- 3) Allow for use of a piece of short, straight suction pipe into the suction port of the pump (minimum length for 40mm diameter suction = 160mm; 50mm diameter suction = 200mm) in order to minimise water turbulence entering the pump.
- 4) Allow for control valves in suction and discharge piping. (Essential if pump is mounted below water level).
- 5) Have adequate floor drainage to prevent pump being immersed in water due to flooding.
- 6) Protect from excess moisture, vermin, dust and weather.
- 7) Allow access for servicing pump and piping.
- 8) To provide adequate ventilation keep rear of motor clear (100mm Min)
- 9) Do not use electrical extension cords/leads.

Operation (Continued)

Priming Pump

Release all air from filter, pump and piping system: refer filter owner's manual. In a flooded suction system (water source higher than pump), pump will prime itself when suction and discharge valves are opened.

If pump is not in a flooded suction system, disconnect power supply to pump and remove hair & lint pot lid; fill casing & bowl with water.

Clean, inspect and lubricate the lid O'ring; reinstall O'ring onto casing & bowl groove.

NOTICE: Apply a silicone based lubricant to the O'ring only. Replace lid onto bowl assembly; turn clockwise to tighten lid.

NOTICE: Tighten lid by hand only (**no wrenches!**)

Pump should prime now. Priming time will depend on vertical height of suction lift and horizontal length of suction piping. The self-priming time range is 1 to 5 minutes for a height difference of 2 to 3 metres, under normal installation conditions. Normal conditions are understood to be: with suction having an internal diameter of DN 50mm, water temperature at 20°C, and 50Hz mains power supply.

Should the pump not prime, ensure that all valves are open, lint trap is clear of debris and suction pipe end is submersed in water, and that there are no leaks in suction pipe.

See Troubleshooting Guide.

Operation



NEVER run pump dry. Running pump dry may damage seals, causing leakage and flooding. Fill pump with water before starting motor.



Before removing lid:

1. **SWITCH OFF POWER SUPPLY** to pump and unplug from outlet before proceeding.
2. **CLOSE SHUT-OFF VALVES** in suction and discharge pipes.
3. **RELEASE ALL PRESSURE** from pump and piping system.
4. **NEVER** tighten or loosen lid while pump is operating!

If pump is being pressure tested, ensure pressure has been released before removing lid.

Do not block pump suction. To do so with body may cause severe or fatal injury. Small children using pool must ALWAYS have close adult supervision.



Fire and burn hazard. Modern motors run at high temperatures. To reduce the risk of fire, do not allow leaves, debris, or foreign matter to collect around the pump motor. To avoid burns when handling the motor, let it cool for at least 20 minutes before trying to work on it.

An internal thermal overload switch protects the motor from heat damage during operation.

NOTICE: Maximum ambient temperature for motor operation must not exceed maximum ambient temperature rating.



This appliance is not intended for use by young children or infirm persons without supervision. Young children should be supervised at all times when near this appliance.

Pool Pump Suction Requirements



Pump suction is hazardous and can trap and drown or disembowel bathers. Do not use or operate swimming pools, spas, or hot tubs if a suction outlet cover is missing, broken, or loose. Follow the guidelines below for a pump installation which minimises risk to users of pools, spas, and hot tubs.

Entrapment Protection

The pump suction system *must* provide protection against the hazard of suction entrapment or hair entrapment/entanglement.

Suction Outlet Covers

All suction outlet covers must be maintained. They must be replaced if cracked, broken, or missing.

See below for outlet cover certification requirements.

All suction outlets must have correctly installed, screw-fastened covers in place.

Testing and Certification

Suction outlet covers must have been tested by a nationally recognised testing laboratory and found to comply with the latest AS1926.3-2003 Standard or the relevant local standard.

Outlets Per Pump

Provide at least two hydraulically balanced main drains, with covers, for each swimming pool pump suction line. The centers of the main drains (suction fittings) must be at least 800mm apart.

The system must be built so that it cannot operate with the pump drawing water from only *one* main drain (that is, there must be at least two main drains connected to the pump whenever it is running). However, if two main drains run into a single suction line, the single suction line may be equipped with a valve which will shutoff *both* main drains from the pump.

More than one pump can be connected to a single suction line as long as the requirements above are met.

Pool Pump Suction Requirements (Continued)

Water Velocity

The maximum water velocity through any suction outlet must be 1.8 metres per second or less unless the outlet complies with the latest AS1926.3-2003 Standard or relevant local standard. In any case, do not exceed the suction fittings maximum designed flow rate.

If 100% of the pump's flow comes from the main drain system, the maximum water velocity in the pump suction hydraulic system must be 1.8 metres per second or less even if one main drain (suction fitting) is completely blocked. The flow through the remaining main drain(s) must comply with the latest AS1926.3-2003 Standard or relevant local standard.

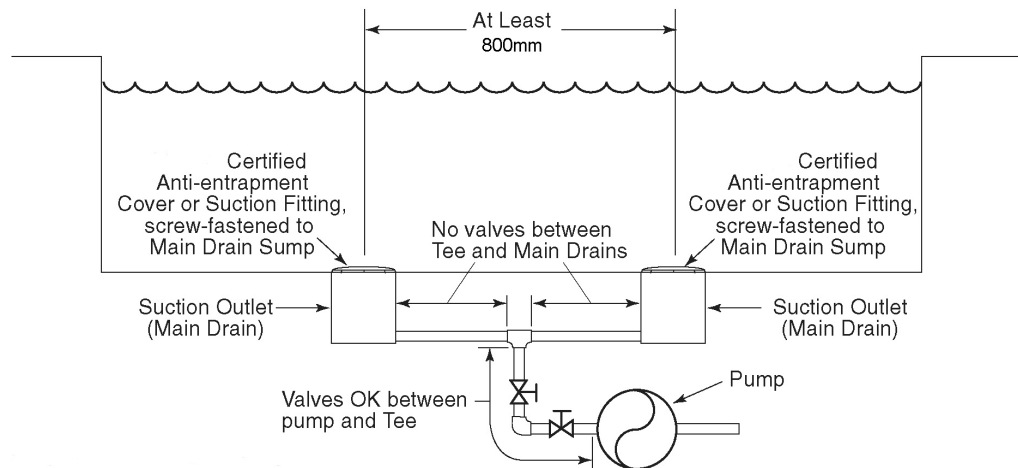

Electrical

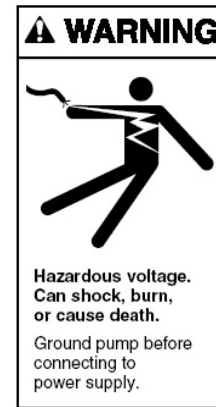

Ground motor before connecting to electrical power supply. Failure to ground motor can cause severe or fatal electrical shock hazard.

Do not ground to a gas supply line.

To avoid dangerous or fatal electrical shock, turn OFF power to motor before working on electrical connections.

Residual Current Device (RCD) tripping indicates an electrical problem. If RCD trips and will not reset, have a qualified electrician inspect and repair electrical system. Onga recommends that a RCD of 30mA trip current be installed and/or be in compliance with local regulations.

Exactly match supply voltage to motor nameplate voltage. Incorrect voltage can cause fire or seriously damage motor and voids warranty. If in doubt consult a licensed electrician.

The power supply lead has a type "Y" connector and if service is required to the power lead, it must be replaced with the appropriate specialised power lead assembly. Warranty is void if unauthorised modifications are made to any component.

240 volt single phase are supplied as standard with built-in thermal overload protection and are designed to plug direct into a 10 amp domestic power supply socket to local electrical authority specifications. Onga recommends that an earth leakage/residual current protection device must be fitted to all installations. 415 volt 3 phase motors should be protected with the recommended contactor and thermal overloads in accordance with local electrical authority specifications

Voltage

Voltage at motor must not be more than 10% above or below motor nameplate rated voltage or motor may overheat, causing overload tripping and reduced component life. If voltage is less than 90% or more than 110% of rated voltage when motor is running at full load, consult power company.